

# 1997 ANNUAL REPORT



High Plains Intermountain  
Center for Agricultural Health and Safety

Colorado  
State  
University

## Director's Statement



*Dr. Roy Buchan*

The High Plains Intermountain Center for Agricultural Health and Safety (HI-CAHS) experienced great success in several areas this past year, but also experienced a

serious set back. The flash flood that occurred on July 28, 1997, devastated the City of Fort Collins and much of the campus of Colorado State University. Three offices housing HI-CAHS staff and graduate students in the Education Building were seriously damaged by flood waters. Although we lost valuable equipment, materials, and resources, we feel very blessed that no one was injured or killed. Along with the rest of the CSU community, we are handling the challenge of recovery and we're moving forward.

This past year saw an increase in funding that will allow us to conduct more research and outreach, and to become fully staffed again after losing one full-time outreach/field person two years ago. HI-CAHS is now one of eight national Agricultural Centers. A top priority during this second five year funding cycle is to increase services throughout the region.

We have learned, since the inception of this program, that it takes time to build a network of support people in the agricultural community. It has taken time for our constituency to know what we do and to become partners in planning. We continue to believe that input from the agricultural community is an extremely important component of our success.

Agriculture remains one of the most hazardous occupations in the country, with a disproportionately high incidence of work-related injuries, disability, disease, and premature death. We have rededicated ourselves to primary prevention and the promotion of a positive state of well-being and health for farmers, ranchers, and field workers on the High Plains and in the Intermountain region. We move into this new year optimistic that we will have greater impact than ever as we put the experience and knowledge from our previous years to good use.

## HI-CAHS Advisory Committee

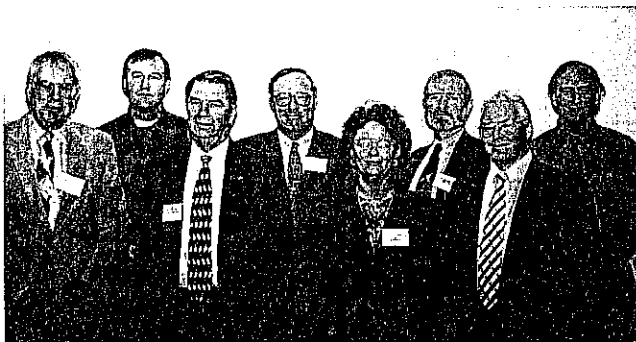

*From Left to Right:*

*Dr. Kirvin Knox, Associate Provost, Colorado State University*

*Mr. Rod Gilmore, North Dakota Department of Health*

*Mr. Buford Rice, Colorado Farm Bureau*

*Mr. Jim Geist, Colorado Corn Growers*

*Ms. Jane McCammon, NIOSH*

*Dr. Dan Farenholtz, Northern Colorado Family Medicine*

*Mr. Greg Baxter, U.S. Department of Labor - OSHA*

*Dr. Ed Hendrickson, Fort Lupton Salud Clinic*

*Not Shown:*

*Mr. Dave Carter, Rocky Mountain Farmers Union*

*Mr. Wayne Cooley, Agronomy Extension Agent*

*Ms. Jennifer Felzeim, Women in Farm Economics*

*Mr. Bill Johnson, Future Farmers of America*

*Dr. W. Dennis Lamm, Cooperative Extension*

*Ms. Sarah K. Robbins-Bramble, St. Mary's Occupational Health Center*

*Mr. Benjie Lemon, Colorado Cattle Feeders Association*

## 1997 Report Contents

Research: Respirable Dust and Crystalline Silica (Quartz) Exposure .....	3
Research: Agricultural Fatalities -- High Plains/Rocky Mountain Region .....	3
Research: Engineering Control Strategies Based on Tractor Stability .....	4
Research: "The Carson's Difficult Decisions," A Narrative Simulation .....	4
Research: Biomarkers of Grain Dust Exposures .....	5
Outreach: Activities with Migrant Workers and Their Families .....	6
Outreach: Education and Training Product Development .....	6
Outreach: Health and Safety Activities .....	7
Program Assessment Resource Development (PAR) .....	8

### HI-CAHS

133 Environmental Health Building

Colorado State University

Fort Collins, CO 80523-1681

(800) 622-8673 or

(970) 491-6152

Fax: (970) 491-7778

E-Mail: [hicaqs@lamar.colostate.edu](mailto:hicaqs@lamar.colostate.edu)

Visit the HI-CAHS Web site at:

<http://www.bernardino.colostate.edu/hicaqs/>

# Research: Respirable Dust and Crystalline Silica (Quartz) Exposure

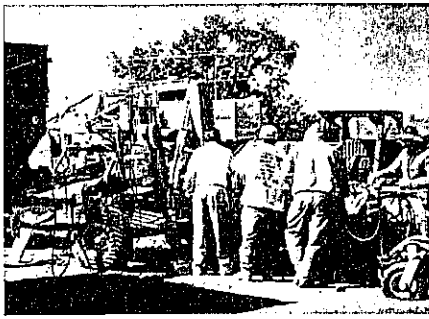

Occupational exposure to silica dust has historically been known to cause chronic respiratory conditions. Workers and workplaces within agricultural industries remain removed from the attention of occupational health and safety agencies. To date, the identification and degree of exposure to respirable dust, crystalline silica, and endotoxins throughout the potato harvesting process have been uncharacterized. A description of the potential

occupational risks in this setting is, therefore, warranted.

The agricultural practices specific to potato harvest, the geographic region, and the soil of the San Luis Valley, are believed to contribute to an occupational risk. The purpose of this research was to identify the components of dust during the fall potato harvest in the San Luis Valley of Southern Colorado. The testing sites were located in three counties in the valley and included seven farming locations. The farm sites were chosen based upon their location, variable soil types, and owner interest. The following parameters were measured: respirable dust (RD) and respirable silica by the 10 mm cyclone, bacterial endotoxins (EU/m<sup>3</sup>) by the Limulus Amoebocyte Lysate (LAL) test, and scanning electron microscopy for particle

identification purposes. All exposures were based upon an eight hour time-weighted average. Exposure impact included the following variables: location of the farming site, soil type (sand, rock, loam), individual job description, weather conditions (wind, rain, wet or dry soil) during harvesting operations, humidity, and temperature.

Results of air monitoring and the identification, classification, and quantification of agricultural worker exposure to these risks have been reported, with a maximum respirable silica (quartz) of 0.105 mg/m<sup>3</sup> identified. This slightly exceeded the ACGIH TLV of 0.10 mg/m<sup>3</sup>. This information will allow employers to recognize where silica dust is generated, and will allow for planning and control implementation to adequately protect workers.

# Research: Agricultural Fatalities – High Plains/Rocky Mountain Region

HI-CAHS researchers have continued collaborating with several National Institute for Occupational Safety and Health (NIOSH) Fatality Assessment and Control Evaluation (FACE) projects in a descriptive study of the region's agricultural work fatality experience. The objectives of this on-going project include: 1) broadening the understanding of the circumstances surrounding agricultural occupational deaths in the states of Colorado, Wyoming, and Nebraska; 2) identifying potential risk factors for agricultural fatalities in the Rocky Mountain and High Plains Region; 3) using this information to correctly target education and injury prevention efforts; and 4) developing a system for regional use of relevant FACE data.

The NIOSH FACE Programs are state-based occupational fatality surveillance efforts that compile information on all fatal traumatic work injuries. To date, 183 fatalities, identified as agricultural-related and occurring since 1989, have been analyzed by HI-CAHS for fatality

type and agent, occupational, geographic, and environmental factors, as well as victim characteristics. Nebraska had 49 agricultural fatalities in a three year period (16.3/yr), Wyoming experienced 18 fatalities in five years (3.6/yr), while Colorado reported 116 fatalities in an eight year period (14.3/yr).

Ninety-six percent of the victims of agricultural work fatalities were male. The median age of victims was 53 years, however, victims ranged in age from 11 to 92 years. Farm machinery such as tractors, loaders, and all-terrain-vehicles were the most frequent

sources of fatal injury overall and in each of the three states. Motor vehicle accidents, falls, electrocution, and large animals, such as cattle and horses, were also frequent causes of fatal traumatic injury (see Figure 1). So far, at least 17 fatalities have been identified as occurring during the harvesting or handling of hay, a major crop for the region. These fatalities included being crushed by falling hay bales, being caught, crushed, or struck by haying machinery, fatal falls from haystacks or haying equipment, and vehicle roll-overs caused by instability from heavy hay loads.

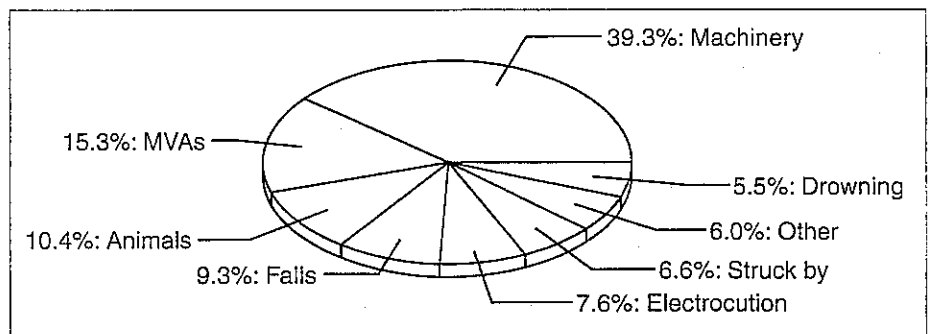

Figure 1: Agricultural fatalities by type from Colorado, Wyoming, and Nebraska FACE projects

# Research: Engineering Control Strategies Based on Tractor Stability



Paul Ayers and Juhua Liu

Agricultural tractor overturns are a leading cause of fatalities in the agricultural industry, resulting in an estimated one out of every five on-farm fatalities (National Safety Council). Although the installation of Rollover Protective Structures (ROPS) can significantly decrease the seriousness of injury during field upsets, it does not prevent the accident from occurring. In addition, certain obstacles (i.e., orchards and low clearance buildings) hinder the utilization of ROPS.

Tractor overturns need to be reduced and operators need to be alerted and/or protected when they are operating in a condition potentially hazardous for a field upset. In addition, deployment of safety control features, including ROPS, restraint systems, stabilizing maneuvers, and/or warnings need to be made based on reliable measurements and models of tractor stability.

The overall objective of this project is to develop and evaluate a tractor stability monitoring system designed for monitoring relative tractor stability and engineering control deployment strategies. The

factors involved in tractor stability include speed, slope, center of gravity, wheel base, tread width, and turning radius. These factors have been used to develop a stability model to determine the degree of stability of tractor operations. A quantitative value referred to as a stability index has been developed from the tractor's physical and operating conditions. The stability index determination incorporates the dynamic measurements, physical tractor characteristics, and stability models to produce an index from 0 to 100. A stability index of 100 indicates high stability (tractor on level terrain with no velocity). A stability index of 0 indicates a tractor operating under conditions where an upset is likely.

Three radio-controlled tractors have been equipped with the stability monitoring system, and field data acquisition has been conducted. The stability monitoring system includes sensors to monitor pitch and roll angle, rate, acceleration, yaw rate, and ground speed. Lateral and longitudinal field testing was conducted on slopes ranging from 10 to 60 degrees at the Agricultural Engineering Research Center. Video technology has been incorporated to assist in the model verification. The application of the stability monitoring system for the deployment of engineering control strategies, accomplished using a pop-up flag as a deployment indicator, has proved successful (see Figure 2).

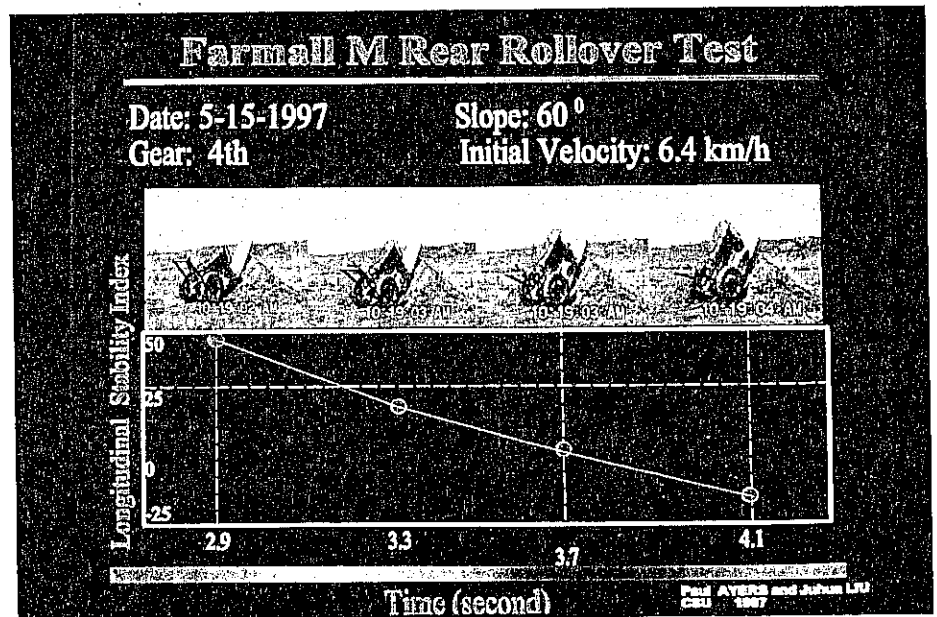

Figure 2: Stability index rear rollover test

## Research: "The Carson's Difficult Decisions," A Narrative Simulation

Narrative simulation exercises have long been used for safety training in a variety of occupational settings. In these types of exercises, participants read and solve problems detailed in a life-like story with a plot, characters, and a safety risk situation similar to what might be encountered at their worksite. Agricultural safety experts at the

University of Kentucky and NIOSH have begun using this innovative technique to increase awareness of farm injury risk factors and for promoting injury prevention attitudes and safe behavior among farmers and their families. In 1995 they developed "The Kayle's Difficult Decisions," which told the story of a Kentucky family with a

small tobacco farm. With the help of individuals from Colorado farm and ranch communities, the original narrative exercise has been adapted by HI-CAHS to, hopefully, more accurately reflect the realities of ranching and farming in the Rocky Mountain West.

(continued on page 5)

(Decisions, continued from page 4)

In "The Carson's Difficult Decisions," the economic consequences of safety decisions are intertwined with common ranch and farm stresses, such as crop production, mounting debt, labor demands, weather, and maintaining equipment. The intended audience is family ranch or farm owners and operators who, as they read and work the story, make decisions about strategies and behaviors to

prevent injury events. The exercise was pre-tested with a small group of ranchers from Northwestern Colorado in September of 1997. These ranchers felt it was an interesting and effective teaching tool, as well as a good alternative to the standard farm safety lecture format. "The Carson's Difficult Decisions" is ready for piloting with this region's agricultural groups and individuals who work with farmers and ranchers.

During this first year, we hope to collect valuable feedback from participants about the effectiveness of this teaching tool, as well as how we might continue to improve the exercise. If you are interested in learning more about "The Carson's Difficult Decisions," or would like to schedule a demonstration of this ranch/farm safety exercise at a meeting, seminar, or other setting, please contact HI-CAHS.

## Research: Biomarkers of Grain Dust Exposures



Greg Cosma and Anthony Martinez

We have developed a human cell model to identify biomarkers of oxidative injury in lung alveolar macrophage (AM) cells exposed to respirable grain dusts. These studies are being pursued in close collaboration with scientists at NIOSH laboratories in Morgantown, W.V. There is a two-fold purpose for performing these studies: 1) to identify major toxic components of grain dusts, and 2) to define underlying pathways of inflammatory lung injury. Airborne respirable wheat and corn dusts were collected at ten grain elevators in Southeastern and Northeastern Colorado during harvest. High-flow air pumps, set at 1.7 L/min, were used with ten cm cyclones to collect dust samples. Samples were analyzed for

levels of bacterial endotoxin via Chromogenic Limulus Amoebocyte Lysate assay, crystalline silica via x-ray diffraction, and 20 metals via inductively coupled plasma/mass spectrometry. Surprisingly, aluminum levels were found to exceed the part-per-thousand level, while iron was the second most common metal detected in grain dusts (see Figure 3).

As expected, endotoxin levels varied with site and grain. However, we have found imperfect correlations between levels of endotoxin contamination in dusts and the severity of the following inflammatory responses in dust-exposed AM cells: 1) production of hydrogen peroxide, and 2) synthesis of

cytokines interleukin-1/6 and TNF-alpha as measured by immunoassay. These studies suggest the presence of other toxic components in grain dusts, possibly related to levels of metals and silica. We have designed a multiple linear regression model to evaluate the strengths of associations between individual components of the dusts and the severity of inflammatory responses in AM cells. Concern over current permissible exposure limits of organic dusts may be partially resolved by identification of their major toxic components. Exposure limits can then be determined by screening for these individual agents, rather than by monitoring total respirable dust mass.

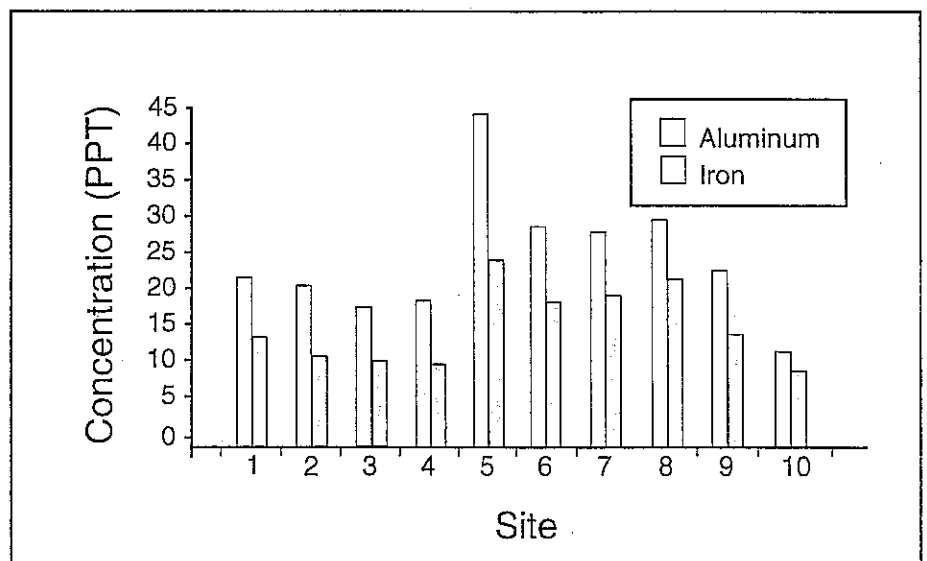

Figure 3: Aluminum and iron concentrations in dust samples



## Outreach: Activities with Migrant Workers and Their Families



Certification under the EPA Worker Protection Standard continues to be a desirable goal in the migrant farm worker population. This helped foster a successful year of training activities. Twenty-four sessions were provided by HI-CAHS staff members, and nearly 800 individuals received training. This is almost twice the number of workers trained in 1996. Attendees

were able to receive information, both written and verbal, in either Spanish or English. The locations of sessions were also more diverse than in the past and included most areas of Colorado.

HI-CAHS staff members also worked closely with the Colorado Head Start Program and the Migrant Education Program in collaborative efforts to provide basic safety and

health training to children enrolled in summer schools. Many of these children were the children of migrant workers. Training topics included chemical safety, farm and machinery safety, and personal hygiene. The children, as usual, were willing and eager participants. Almost 500 participated in the nine sessions during the summer.

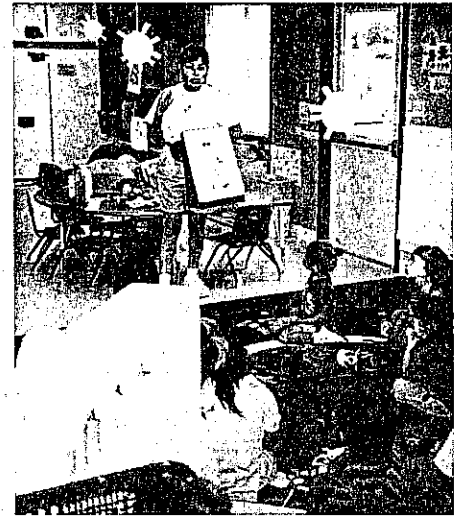

## Outreach: Education and Training Product Development



Don Quick and Bart Beaudin

### Information Dissemination Display

HI-CAHS received "Best of Show" and "Most Informative" awards for our poster at the NIOSH Agricultural Health and Safety Conference in Morgantown, West Virginia, July 15-17, 1997. This is one of several posters developed to

assist in the communication and distribution of information to our various constituents.

### Information Sheets

A new product line was developed this year, to help us distribute needed information to our clients.

Two information sheets were developed with more to come in 1998. These informative sheets can be downloaded from our

web site and are also available in hard copy from HI-CAHS. The first is *Air-Purifying Respirators (IS-97-01)*, which gives a brief description of when to use a respirator and what type to use, and also provides information on the care and maintenance of respirators. The second information sheet

is titled *Farm Fatality Reminder Of Electrocution Danger Associated With Aluminum Irrigation Piping (IS-97-02)*. It warns of the hazard of overhead power lines when handling aluminum irrigation piping and includes a warning label that can be placed on pipes as a safety reminder.

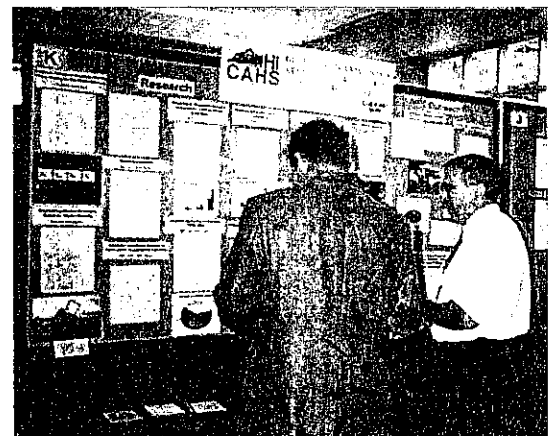

Bart Beaudin provides an overview of center activities and products to an unidentified conference participant.

# Outreach: Health and Safety Activities



Martha Vela, Lori Berberet, Del Sandfort

1997 was a year of transition for HI-CAHS outreach programs. All of the original health and safety staff members have gone on to other professional activities, and we started over with a new health and safety specialist.

## Training and Education

The Outreach Program conducted 58 training and education activities reaching more than 2,600 people. Twenty-four of these sessions were specifically tailored to provide worker training under the EPA Worker Protection Standard. These activities were conducted at labor camps and attended by the migrant workers living at the housing areas. Other sessions were very diverse. Topics ranged from general agricultural health and safety to ergonomics. Most audi-

ences requested more general training that covered mechanical, chemical, and physical hazards and their control.

The Colorado Corn Growers Association invited HI-CAHS staff members to participate in a very unique training session. As part of a large gathering and exhibit, this group staged a corn harvester accident. A farmer pretended to be entrapped in a corn head; emergency response was called, and the victim was extricated in front of many exhibit attendees. The entire "accident" was filmed, as was a discussion of the safety issues associated with the event. Other health and safety topics were also discussed. From this event, the Corn Growers and HI-CAHS now have a high-quality video that can be used for additional training. This group, and many others, have recognized the importance of health and safety as a cost issue. Many training activities are taking place in an effort to contain Worker Compensation insurance costs, as well as the direct and indirect costs of an accident or fatality.

## Hazard Surveys

As people become aware of health and safety issues through training and education, they tend to realize the importance of on-site

assistance provided by HI-CAHS. Requests for health and safety hazard surveillance continue as a direct result of training efforts. In 1997, 15 comprehensive hazard surveys were performed at farms and agricultural businesses. Nearly 500 workers were exposed to hazards at these locations. Issues of machine guarding have been, and continue to be, the most common finding during these surveys. However, a significant number of hazards associated with electrical safety, chemical handling and personal protective equipment, and general housekeeping have been identified.

Hazard control or elimination has been the primary goal of this activity. However, a systematic approach to maintaining a workplace free from hazards is also necessary. HI-CAHS staff members work closely with owners and operators to assist them in the development of comprehensive health and safety programs. The implementation of these programs allows the operation to maintain a culture that is conducive to health and safety and prevents the recurrence of workplace hazards. It also saves money through reduction of accidents and illnesses, as well as insurance premiums.

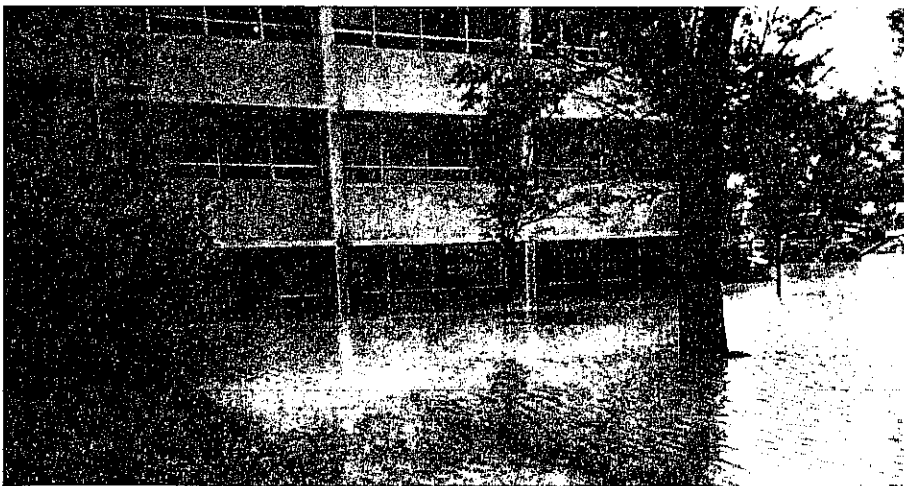

## Flood Focus

Much of our focus, since July 28, has been to reestablish the archives and resources lost during the Fort Collins flood that heavily impacted the Colorado State University campus, and the Program Assessment Resource Development (PARD) and education units in particular.

# Program Assessment Resource Development (PARD)



*Vicky Buchan, Sue Hewitt, Tammy Brannen-Smith, Sue Tungate*

## Special Evaluation Projects

The program assessment and resource development unit of HI-CAHS has undertaken a number of exciting and varied activities during the last year. We continue to monitor Center activities in order to report Center accomplishments to NIOSH. These activities include research projects, publications, outreach, and educational activities.

A number of special evaluation projects were targeted towards Center projects that are key to serving the various target popula-

tions of interest. One project, for example, sought to evaluate the outreach education and prevention efforts offered to the children of migrant laborers. Another evaluation project was a five-year review of HI-CAHS Worksite Hazard Consultation services.

## Collaborative Approach to Multisite Evaluation

A major objective for this year has been the initiation of a collaborative approach to multisite evaluation for all of the Agricultural Health and Safety Centers. On May 3 and 4 of 1997, PARD hosted a workshop for evaluation representatives from NIOSH and seven of the eight national Centers. The workshop provided an opportunity for Center evaluators to meet one another and to begin discussions on what could be a viable multisite evaluation model. A number of evalua-

tion tools which would help NIOSH develop an overview of Center initiative accomplishments were proposed during the workshop. While Center differences do create challenges for the collaborative process, workshop participants were highly motivated to share experiences, perceptions, and ideas. Collaboration among group members has continued through group conference calls thanks to the continued support and encouragement of our NIOSH collaborator, Teri Palermo.



*Discussion at the Multisite Workshop. From left to right: Marian McDonald, Nancy Young, Henry Cole, Rose Krebill-Prather*

## HI-CAHS Web Site

New for 1997, the web site was established to provide online access to information about HI-CAHS activities and products. It has the potential to become one of the key elements of our information dissemination plan to get current information to the field and in the hands of practitioners as quickly as possible. Information sheets developed by specialists have immediate online availability.

### Web Address:

<http://www.bernardino.colostate.edu/hicahs/>

To request additional copies of this report, to update your mailing address, or to be removed from our mailing list, please contact us at (800) 622-8673.

*Colorado State University is an equal opportunity/affirmative action institution and complies with all Federal and Colorado State laws, regulations, and executive orders regarding affirmative action requirements in all programs. The Office of Equal Opportunity is located in Room 101, Student Services Building. In order to assist Colorado State University in meeting its affirmative action responsibilities, ethnic minorities, women, and other protected class members are encouraged to apply and to so identify themselves.*