

A STRUCTURAL CHARACTERIZATION
OF SQUARE FREE HOMOMORPHISMS

by

A. Ehrenfeucht*

and

G. Rozenberg**

CU-CS-229-82

September, 1982

*Department of Computer Science University of Colorado at
Boulder, Boulder, Colorado 80309

**Institute of Applied Mathematics and Computer Science,
University of Leiden, Leiden, The Netherlands

All correspondence to second author.

This research was supported by NSF grant MCS 79-03838.

ANY OPINIONS, FINDINGS, AND CONCLUSIONS
OR RECOMMENDATIONS EXPRESSED IN THIS
PUBLICATION ARE THOSE OF THE AUTHOR AND
DO NOT NECESSARILY REFLECT THE VIEWS OF THE
NATIONAL SCIENCE FOUNDATION.

THIS MATERIAL IS BASED UPON WORK SUPPORTED
IN PART BY THE NATIONAL SCIENCE FOUNDATION
UNDER GRANT NO. MCS 79-03838

ABSTRACT

A nonempty word x over an alphabet Σ is called a *square* if $x = x_1 y y x_2$ for some $x_1, x_2 \in \Sigma^*$ and $y \in \Sigma^+$; otherwise x is called *square free*. $SF(\Sigma^+)$ denote the set of all square free words over Σ . A homomorphism $h: \Sigma^+ \rightarrow \Delta^+$ is called *square free* if $h(SF(\Sigma^+)) \subset SF(\Delta^+)$. We prove the following structural characterization of square free homomorphisms:

a homomorphism $h: \Sigma^+ \rightarrow \Delta^+$ is square free if and only if $h(TEST_h) \subset SF(\Delta^+)$, where

$TEST_h = \{w \in SF(\Sigma^+): |w| \leq 3\} \cup \{w \in SF(\Sigma^+): |w| > 3 \text{ and there exist } a, b \in \Sigma$
and $u \in \Sigma^+$ such that $w = aub$ and either $h(u)$ is a subword of $h(a)$ or
 $h(u)$ is a subword of $h(b)\}$.

Several consequences of this result are discussed.

INTRODUCTION

Repetitions of subwords in words form the very basic combinatorial structure of formal languages. The investigation of this topic was initiated by A. Thue in [T] and since then it was a subject of very active research in numerous areas of mathematics and in formal language theory (see, e.g., [BEM], [C], [D], [MH], and [S1]). The recent revival of interest in this topic among formal language theorists (see, e.g., [Br], [Cr], [ER], [K], and [S2]) was initiated by [B] where Berstel once again stresses the role of square free homomorphisms in the investigation of various properties of square free words.

In our paper we provide a structural characterization of square free homomorphisms and indicate the use of our result in the research concerning "Thue problems".

PRELIMINARIES

We assume the reader to be familiar with the basic terminology concerning formal languages. Perhaps the following (mostly notational) matters require an additional comment.

For a finite set Z , $\#Z$ denotes its cardinality.

For a real n , $\lfloor n \rfloor$ denotes the biggest integer smaller than or equal n and $\lceil n \rceil$ denotes the least integer greater than or equal n .

For a word x , $|x|$ denotes its length, $alph(x)$ denotes the set of symbols appearing in x , $first(x)$ denotes the first letter of x and $last(x)$ denotes the last letter of x . Λ denotes the empty word.

A word x is a *subword* of a word y if $y = y_1xy_2$ for some words y_1, y_2 ; we write x *sub* y (sometimes the term *segment* rather than a subword is used). If $y_1 = \Lambda$ then x is a *prefix* of y written x *pref* y ; if additionally $y_2 \neq \Lambda$ then x is a *strict prefix* of y written x *spref* y . If $y_2 = \Lambda$ then x is a *suffix* of y written x *suf* y ; if additionally $y_1 \neq \Lambda$ then x is a *strict suffix* of y written x *ssuf* y . If x *pref* y then $x \setminus y$ denotes the word obtained from y by removing its prefix x ; if x *suf* y then y / x denotes the word obtained from y by removing its suffix x . If $x \neq \Lambda$, $y = y_1x$ and $z = xz_1$ for some words y_1 and z_1 then we say that z and y *have a common border*, x is referred as a *border* of y and z .

If $x \neq \Lambda$ and xx *sub* y then y is called a *square*, otherwise y is called *square free*; for an alphabet Σ , $SF(\Sigma^+)$ denotes the set of all nonempty square free words over Σ .

For a homomorphism $h: \Sigma^+ \rightarrow \Delta^+$, $minr(h) = \min\{|h(a)| : a \in \Sigma\}$,

$maxr(h) = \max\{|h(a)| : a \in \Sigma\}$ and $rat(h) = \frac{maxr(h)}{minr(h)}$.

If $rat(h) = 1$ then h is called *uniform*.

In order to simplify the notation and to avoid very cumbersome formulations we will often not distinguish between subwords and their occurrences in

words (this is quite customary in formal language theory). This should not lead to a confusion because the exact meaning should be always clear from the context; moreover to avoid misunderstanding we often provide figures that illustrate the situations considered.

1. THE MAIN THEOREM

In this section we prove a theorem providing a structural characterization of square free homomorphisms.

Theorem 1. Let $h: \Sigma^+ \rightarrow \Delta^+$ be a homomorphism, let

$T_3 = \{w \in SF(\Sigma^+): |w| \leq 3\}$ and let

$T_h = \{w \in SF(\Sigma^+): \text{there exist } a, b \in \Sigma \text{ and } u \in \Sigma^* \text{ such that } w = a u b \text{ and either } h(u) \text{ sub } h(a) \text{ or } h(u) \text{ sub } h(b)\} \cup \Sigma$.

Then h is square free if and only if $h(T_3 \cup T_h) \subset SF(\Delta^+)$.

Proof.

The "if" part of the statement of the theorem is obvious.

To prove the "only if" part of the statement of the theorem we proceed as follows.

Let $h: \Sigma^+ \rightarrow \Delta^+$ be a homomorphism such that $h(T_3 \cup T_h) \subset SF(\Delta^+)$.

Lemma 1. If h is not square-free and $h(T_h) \subset SF(\Delta^+)$, then $h(T_3) \not\subset SF(\Delta^+)$.

Proof of Lemma 1:

Let us assume that:

h is not square free and $h(T_h) \subset SF(\Delta^+)$(1)

The proof of the conclusion of Lemma 1 goes through a sequence of lemmas.

Lemma 1.1. If $w \in SF(\Sigma^+)$ and $|w| \leq 2$, then $h(w) \in SF(\Delta^+)$.

Proof of Lemma 1.1:

All words satisfying the assumption of the statement of Lemma 1.1 are in T_h . Hence Lemma 1.1 follows from (1). ■

Lemma 1.2. If $a, b \in \Sigma$ are such that $h(a)$ and $h(b)$ have a common border, then $a = b$.

Proof of Lemma 1.2:

If we assume that $a \neq b$, then $h(ab) = x z z y$ is a square. This however contradicts Lemma 1.1. Thus Lemma 1.2 holds. ■

Let $w = w_1 u w_2$ and $h(w) = z_1 z z_2$ where $w_1, w_2 \in \Sigma^*$, $u \in \Sigma^+$, $z_1, z_2 \in \Delta^*$ and $z \in \Delta^+$ are such that

- (i) $h(w_1) \text{ pref } h(z_1)$,
- (ii) $h(w_2) \text{ suf } h(z_2)$,
- (iii) $z \text{ sub } h(u)$, and
- (iv) neither $z \text{ sub } h(\text{first}(u) \setminus u)$ nor $z \text{ sub } h(u / \text{last}(u))$.

Then (the depicted occurrence of) u is the *contributor of* (the depicted occurrence of) z in $h(w)$ and denoted by $C_h(w, z)$. To simplify the notation we write $C_h(w, z)$ rather than $C_h(w, z, z_1, z_2)$; we can do so because in the sequel of the paper whenever the notation $C_h(w, z)$ is used z_1 and z_2 are clear from the context.

Thus $C_h(w, z)$ is the minimal (occurrence of a) subword in w that contributes the given occurrence of z in $h(w)$. The situation can be illustrated as follows:

Figure 1

Lemma 1.3. Let $a \in \Sigma$. If $h(a) = z u z$ for some $z \in \Delta^+$ and $u \in \Delta^*$ then for each $b \in \Sigma$ neither $h(b) \text{ pref } uz$ nor $h(b) \text{ suf } zu$.

Proof of Lemma 1.3:

Assume to the contrary that the conclusion of the statement of Lemma 1.3 is not true. That is there exists a letter $b \in \Sigma$ such that

either (i) $h(b) \text{ pref } uz$

or (ii) $h(b) \text{ suf } zu$.

Assume that (i) holds.

Consider the word $w = aba$; clearly $w \in T_h$. Then

$$\begin{aligned} h(w) &= h(a) h(b) h(a) \\ &= z u z h(b) z u z \\ &= z u z h(b) z h(b) y \end{aligned}$$

for some $y \in \Delta^*$.

Consequently $h(w) \notin SF(\Delta^+)$. But obviously $w \in T_h$ and so we get a contradiction to the assumption (1).

Similarly if we assume that (ii) holds we get a contradiction (to (1)).

Thus neither (i) nor (ii) can be true and consequently Lemma 1.3 holds. ■

Lemma 1.4. Let $w \in SF(\Sigma^+)$ and let $h(w) = z_1 x_1 x_2 z_2$ where $x_1 = x_2 \neq \Lambda$. Then $|C_h(w, x_1)| > 1$ and $|C_h(w, x_2)| > 1$.

Proof of Lemma 1.4:

Assume to the contrary that

$$(i) |C_h(w, x_1)| = 1.$$

By Lemma 1.1, $|C_h(w, x_1 x_2)| > 2$. Thus $C_h(w, x_1 x_2) = a u b$ for some $a, b \in \Sigma$ and $u \in \Sigma^+$. The situation can be illustrated as follows:

Figure 2

Thus $h(u)$ *sub* x_2 while $x_2 = x_1$ and x_1 *sub* $h(a)$. Hence $h(u)$ *sub* $h(a)$ and consequently $C_h(w, x_1 x_2) = a u b \in T_h$. Thus by (1), $h(C_h(w, x_1 x_2))$ is not a square; a contradiction. Hence (i) cannot hold.

Analogously we show that the assumption

$$(ii) |C_h(w, x_2)| = 1$$

leads to a contradiction.

Consequently $|C_h(w, x_1)| > 1$ and $|C_h(w, x_2)| > 1$ and Lemma 1.4 holds. ■

Let $w \in SF(\Sigma^+)$ be such that $|w| \geq 2$ and let $u \in \Delta^+$. Then w is an h -parsing of u if $h(w) = z_1 u z_2$, for some $z_1, z_2 \in \Delta^*$, and $C_h(w, u) = w$.

The set of all h -parsings of u will be denoted by $parse_h(u)$.

Let $w = w_1 z w_2$, for some $w_1, w_2 \in \Sigma^*$ and $z \in \Sigma^+$, and let $h(w) = u_1 u u_2$ for some $u_1, u_2 \in \Delta^*$ and $u \in \Delta^+$. Then $D_h(w, z, u)$ denotes this part of (the given occurrence of) u that is "contributed by" (the given occurrence of) z .

Let $w_1, w_2 \in parse_h(u)$. We say that w_1, w_2 are (h, u) -equivalent, written as $w_1 \underset{h,u}{\sim} w_2$, if $w_1 = a_1 \cdots a_k$, $w_2 = b_1 \cdots b_k$, for some $k \geq 2$ and $a_1, \dots, a_k, b_1, \dots, b_k \in \Sigma$, where $D_h(w, a_i, u) = D_h(w, b_i, u)$ for all $1 \leq i \leq k$.

The situation can be illustrated as follows:

Figure 3

Lemma 1.5. Let $w_1, w_2 \in \Sigma^+$ and $u \in \Delta^+$ be such that $w_1, w_2 \in parse_h(u)$. Then either $|w_1| = |w_2| = 2$ or $w_1 \underset{h,u}{\sim} w_2$.

Proof of Lemma 1.5:

Let $w_1 = a_1 \cdots a_k$ and $w_2 = b_1 \cdots b_m$ for some $k, m \geq 2$ and $a_1, \dots, a_k, b_1, \dots, b_m \in \Sigma$.

To prove the lemma we will assume that

it is not true that $w_1 \underset{h,u}{\sim} w_2$(2)

and then we will demonstrate that $|w_1| = |w_2| = 2$.

Claim 1.5.1 $D_h(w_1, a_1, u) \neq D_h(w_2, b_1, u)$.

Proof of Claim 1.5.1:

Assume to the contrary that

$$D_h(w_1, a_1, u) = D_h(w_2, b_1, u) \dots \dots \dots (3)$$

Then we demonstrate that, for each $1 \leq i \leq |w_1|$

$$D_h(w_1, a_i, u) = D_h(w_2, b_i, u) \dots \dots \dots (4)$$

This is proved by induction on i as follows.

By (3), (4) holds for $i = 1$.

Assume that (4) holds for all $1 \leq i \leq q$ for some $q < |w_1|$.

Then, by Lemma 1.2 it must be that $D_h(w_1, a_{q+1}, u) = D_h(w_2, b_{q+1}, u)$ and consequently (4) holds.

But (4) implies that $w_1 \underset{h,u}{\sim} w_2$ which contradicts (2). Consequently (3) cannot hold and Claim 1.5.1 is proved. ■

In view of Claim 1.5.1 either $D_h(w_1, a_1, u) \text{ spre } D_h(w_2, b_1, u)$ or $D_h(w_2, b_1, u) \text{ spre } D_h(w_1, a_1, u)$.

We will assume that $D_h(w_1, a_1, u) \text{ spre } D_h(w_2, b_1, u)$; the other situation can be handled analogously.

Let $\text{last}(D_h(w_2, b_1, u)) = e$.

Since $|w_2| \geq 2$, this e cannot be the last letter in u . Let d be a letter in u which is immediately to the right of e and let $1 < t \leq |w_1|$ be such that $D_h(w_1, a_t, u)$ includes e . Note that then $D_h(w_1, a_t, u)$ also includes d as otherwise by Lemma 1.2 it must be that $t = 1$; a contradiction.

Hence we have the following situation:

Figure 4

Consequently $h(a_t)$ and $h(b_1)$ have a common border (let z be the border resulting from the overlapping of $h(a_t)$ and $h(b_1)$ in the situation considered) and by Lemma 1.2 a_t and b_1 are occurrences of the same letter. Thus

$h(b_1) = z g z$ for some g .

Claim 1.5.2. $t = 2$.

Proof of Claim 1.5.2:

Assume to the contrary that $t > 2$.

Then $t-1 > 1$ and $h(a_{t-1}) \text{ suf } zg$. This however contradicts directly Lemma 1.3.

Thus it must be that $t = 2$ and Claim 1.5.2 holds. ■

Claim 1.5.3. $|w_1| = 2$.

Proof of Claim 1.5.3:

Assume to the contrary that $|w_1| > 2$(5)

Let $\text{last}(D_h(w_1, a_2, u)) = r$.

Then (5) implies that this (occurrence of) r cannot be the last (occurrence of a) letter in u . Let s be (an occurrence of a) letter in u which is immediately to the right of r and let $1 < \bar{t} \leq |w_2|$ be such that $D_h(w_2, b_{\bar{t}}, u)$ includes (the given occurrence of) r .

Reasoning as above (see the argument following Claim 1.5.1) we prove that $D_h(w_2, b_{\bar{t}}, u)$ must also include s and moreover a_2 and $b_{\bar{t}}$ must be occurrences of the same letter. Then analogously to the proof of Claim 1.5.2 we demonstrate that $\bar{t} = 2$.

Thus b_1 and a_2 are occurrences of the same letter and a_2 and b_2 are occurrences of the same letter. Consequently b_1 and b_2 are occurrences of the same letter which implies that w_2 is a square; a contradiction.

Thus (5) cannot hold and Claim 1.5.3 is proved. ■

Claim 1.5.4 $|w_2| = 2$.

Proof of Claim 1.5.4:

Assume to the contrary that $|w_2| > 2$(6)

Then in view of Claim 1.5.3 we have the following situation:

Figure 5

where z is the border resulting from the overlapping of $h(a_2)$ and $h(b_1)$;
hence $h(b_1) = z g z$ for some g .

Hence $h(b_2) \text{ pref } gz$ which contradicts Lemma 1.3. Consequently (6) cannot hold. Thus $|w_2| = 2$ and Claim 1.5.4 is proved. ■

Now Lemma 1.5 follows from Claim 1.5.3, Claim 1.5.4 and our assumption (2). ■

Using lemmas 1.1 through 1.5 we complete the proof of Lemma 1 as follows.

Let $y \in SF(\Sigma^+)$ be such that $h(y) \notin SF(\Delta^+)$, say $h(y) = x_0 x_1 x_2 x_3$ where $x_1 = x_2 \in \Delta^+$. (Since h is not square free such a word y exists). Consider now $C_h(y, x_1 x_2)$. Lemma 1.4 implies that the first (occurrence of a) letter of $C_h(y, x_1 x_2)$ does not contribute the last (occurrence of a) letter of x_1 , and the last (occurrence of a) letter of $C_h(y, x_1 x_2)$ does not contribute the first (occurrence of a) letter of x_2 .

Thus we have two cases to consider.

Case 1. $C_h(y, x_1 x_2) = y_1 y_2$, where $y_1 = C_h(y, x_1) = a_1 \cdots a_k$
and $y_2 = C_h(y, x_2) = b_1 \cdots b_n$ for $k, n \geq 2$ and $a_1, \dots, a_k, b_1, \dots, b_n \in \Sigma$.

In this case we have the following situation:

Figure 6

In this case $y_1, y_2 \in \text{parse}_h(x)$ where $x = x_1 = x_2$. By Lemma 1.5 either $y_1 \underset{h,x}{\sim} y_2$ or $|y_1| = |y_2| = 2$.

Assume first that

$$y_1 \underset{h,x}{\sim} y_2 \dots \dots \dots (7)$$

Then $k = n$, $D_h(y_1, a_1, x) = D_h(y_2, b_1, x)$ and $D_h(y_1, a_n, x) = D_h(y_2, b_n, x)$. Consequently $h(a_1)$ has a common border with $h(b_1)$ and $h(a_n)$ has a common border with $h(b_n)$. Thus by Lemma 1.2 it must be that $a_1 = b_1$, $a_2 = b_2$ and, for each $q \in \{2, \dots, k-1\}$, $a_q = b_q$.

But this implies that $y_1 = y_2$ and so y is a square; a contradiction.

Thus (7) cannot hold.

Assume then that

$$|y_1| = |y_2| = 2 \dots \dots \dots (8)$$

Thus $k = n = 2$.

Lemma 1.6. $|D_h(y_2, b_1, x)| < |D_h(y_1, a_1, x)|$.

Proof of Lemma 1.6:

Assume first that

$$|D_h(y_2, b_1, x)| = |D_h(y_1, a_1, x)| \dots \dots \dots (9)$$

Then obviously $|D_h(y_2, b_2, x)| = |D_h(y_1, a_2, x)|$ and so by Lemma 1.2 we get $a_1 = b_1$ and $a_2 = b_2$. Consequently y is a square (it contains the subword $a_1 a_2 b_1 b_2 = a_1 a_2 a_1 a_2$); a contradiction.

Thus (9) cannot hold.

Assume then that

$$|D_h(y_2, b_1, x)| > |D_h(y_1, a_1, x)| \dots \dots \dots (10)$$

Then $h(b_1)$ and $h(a_2)$ contain a common border and so by Lemma 1.2 it must be that $b_1 = a_2$. Consequently y is a square; a contradiction.

Thus (10) cannot hold.

Since neither (9) nor (10) holds, Lemma 1.6 holds. ■

Thus we have the following situation:

Figure 7

Thus $h(a_1)$ and $h(b_2)$ have the common border, let \bar{z} be the border resulting from the overlapping of $h(a_1)$ and $h(b_2)$. Hence by Lemma 1.2 we have $a_1 = b_2$. Moreover we can write $D_h(y_1, a_1, x)$ in the form $\bar{z} \bar{g} \bar{z}$ for some $\bar{g} \in \Delta^*$. Then however we have $h(b_1) \text{ suf } \bar{g} \bar{z}$ which contradicts Lemma 1.3.

Consequently we arrive at the conclusion that *Case 1* cannot hold.

Hence the following must hold.

Case 2. $C_h(y, x_1 x_2) = y_1 a y_2$, where $a \in \Sigma, y_1 = a_1 \cdots a_k, y_2 = b_1 \cdots b_n$, $C_h(y, x_1) = y a, C_h(y, x_2) = a y_2$, for $k, n \geq 2$ and $a_1, \dots, a_k, b_1, \dots, b_n \in \Sigma$.

Then $y_1 a, a y_2 \in \text{parse}_h(x)$.

Thus we have the following situation:

Figure 8

By Lemma 1.5, either $y_1 a \underset{h,x}{\sim} a y_2$ or $|y_1 a| = |a y_2| = 2$

Assume first that

$$y_1 a \underset{h,x}{\sim} a y_2 \dots \dots \dots (11)$$

Then $k = n, \alpha = D_h(y_1, a_1, x_1) = D_h(y, a, x_2) = \delta$ and $\beta = D_h(y, a, x_1) = D_h(y_2, b_k, x_2) = \gamma$. Also, by Lemma 1.2, $a_q = b_{q-1}$ for each $1 < q \leq k$.

If $a_1 = a$ then $a_1 \cdots a_k = a b_1 \cdots b_{k-1}$ and if $b_k = a$ then $a_2 \cdots a_k a = b_1 \cdots b_{k-1} b_k$. Thus in both cases y is a square. Consequently

$$a_1 \neq a \text{ and } b_k \neq a \dots\dots\dots(12)$$

By (12), the word $a_1 a b_k$ is square free. Then

$$\begin{aligned} h(a_1 a b_k) &= h(a_1) \beta \delta h(b_k) = z_1 \alpha \beta \delta \gamma z_2 \\ &= z_1 \alpha \beta \alpha \beta z_2 \end{aligned}$$

for some $z_1, z_2 \in \Delta^*$.

Thus we have $|a_1 a b_k| = 3$ and $h(a_1 a b_k) \notin SF(\Delta^+)$.

Consequently

$$\text{if (11) holds then } h(T_3) \not\subset SF(\Delta^+) \dots\dots\dots(13)$$

$$\text{Assume now that } |y_1 a| = |a y_2| = 2 \dots\dots\dots(14)$$

Then $|C_h(y, x_1 x_2)| = |a_1 a b_n| = 3$ while $h(C_h(y, x_1 x_2))$ is a square. Consequently

$$\text{if (14) holds, then } h(T_3) \not\subset SF(\Delta^+) \dots\dots\dots(15)$$

Since *Case 2* must hold, Lemma 1.5 together with (13) and (15) implies Lemma 1. ■

Clearly Lemma 1 implies the "only if" part of the statement of the theorem.

Thus the theorem holds. ■

We can restate the theorem in a somewhat "neater" form expressing the set $T_3 \cup T_h$ in a more transparent form.

Let, for a homomorphism $h: \Sigma^+ \rightarrow \Delta^+$,

$$\begin{aligned} TEST_h &= T_3 \cup \{w \in SF(\Sigma^+): |w| > 3 \text{ and there exist } a, b \in \Sigma \text{ and } u \in \Sigma^+ \\ &\quad \text{such that } w = a u b \text{ and either } h(u) \text{ sub } h(a) \\ &\quad \text{or } h(u) \text{ sub } h(b)\}. \end{aligned}$$

Theorem 1'. Let $h: \Sigma^+ \rightarrow \Delta^+$ be a homomorphism. Then h is square free if and only if $h(TEST_h) \subset SF(\Delta^+)$.

Proof:

Follows immediately from Theorem 1 and the fact that $T_3 \cup T_h = TEST_h$. ■

2. DISCUSSION

In this paper we have provided a structural characterization of square free homomorphisms. We will demonstrate now how our main result is related to some other results encountered in the literature concerned with the topic of square free homomorphisms.

(1) In his seminal paper [T] Thue provides the following sufficient condition for a homomorphism to be square free.

Proposition 1. Let $h: \Sigma^+ \rightarrow \Delta^+$ be a homomorphism. If

(i) for each $a, b \in \Sigma$, $h(a) \text{ sub } h(b)$ implies $a = b$, and

(ii) $h(T_3) \subset SF(\Delta^+)$

then h is square free. ■

This proposition follows immediately from Theorem 1: if a homomorphism $h: \Sigma^+ \rightarrow \Delta^+$ satisfies the condition (i) above then $T_h = \{ab: a, b \in \Sigma \text{ and } a \neq b\} \cup \Sigma$ and consequently $T_h \subset T_3$; thus by Theorem 1 the condition (ii) above implies that h is square free.

(2) In [B] Berstel provides the following "numerical" characterization of square free homomorphisms.

Proposition 2. Let $h: \Sigma^+ \rightarrow \Delta^+$ be a homomorphism. Then h is square free if and only if $h(w) \in SF(\Delta^+)$ for each $w \in SF(\Sigma^+)$ such that $|w| \leq \lfloor 2 \text{rat}(h) \rfloor + 2$. ■

Using Theorem 1 we can improve the Berstel bound (on the length of words to be tested by a homomorphism for establishing its square freeness).

Lemma 2. Let $h: \Sigma^+ \rightarrow \Delta^+$ be a homomorphism. If $w \in T_3 \cup T_h$ then $|w| \leq \lfloor \text{rat}(h) \rfloor + 2$.

Proof:

Let $w \in T_3 \cup T_h$.

If $|w| \leq 3$ then $|w| \leq \lceil \text{rat}(h) \rceil + 2$ and so in this case the lemma holds.

Thus assume that $|w| > 3$; hence either $w = a u b$ or $w = b u a$ where $a, b \in \Sigma, u \in \Sigma^+$ and $h(u) \text{ sub } h(a)$. Then $|h(u)| \leq |h(a)| \leq \text{maxr}(h)$. Since $|u| \text{minr}(h) \leq |h(u)|$ we get $|u| \leq \frac{|h(u)|}{\text{minr}(h)} \leq \frac{\text{maxr}(h)}{\text{minr}(h)}$ and consequently $|u| \leq \lceil \text{rat}(h) \rceil$. Thus $|w| = |u| + 2 \leq \lceil \text{rat}(h) \rceil + 2$ and so the lemma holds also for all $w \in T_3 \cup T_h$ such that $|w| > 3$.

Consequently Lemma 2 holds. ■

Now Theorem 1 and Lemma 2 yield the following result.

Theorem 2. Let $h: \Sigma^+ \rightarrow \Delta^+$ be a homomorphism. Then h is square free if and only if $h(w) \in SF(\Delta^+)$ for each $w \in SF(\Sigma^+)$ such that $|w| \leq \lceil \text{rat}(h) \rceil + 2$. ■

Since $\lfloor 2\text{rat}(h) \rfloor \geq \lceil \text{rat}(h) \rceil + 1$, Theorem 2 provides a better bound than Berstel theorem. Moreover our bound is optimal: in [Br] the homomorphism $h: \{a, b, c\}^+ \rightarrow \{a, b, c\}^+$ defined by $h(a) = ab, h(b) = cb, h(c) = cd$ is discussed; it is easily seen that $h(w)$ is square free for all $w \in \{a, b, c\}^+$ such that $|w| \leq 2$ however the word $h(abc) = a b c b c d$ is not square free.

(3) After we have obtained our main result, we have learned of the paper [Cr] by M. Crochemore. It provides several interesting results concerning square free homomorphisms. We were not able to relate directly theorems 1 and 2 from [Cr] to our main result. We would like however to observe the following.

(3.1) The following result is announced in the introduction of [Cr] as its main result.

Proposition 3. Let $h: \Sigma^+ \rightarrow \Delta^+$ be a homomorphism where $\#\Sigma = 3$. Then h is square free if and only if $h(w) \in SF(\Delta^+)$ for each $w \in SF(\Sigma^+)$ such that $|w| \leq 5$.

■

This result provides a "homomorphism independent" characterization of square free homomorphisms over the 3-letter alphabets. It follows from our Theorem 1 as follows.

Let $T_5 = \{w \in SF(\Sigma^+) : |w| \leq 5\}$.

Lemma 3. Let $h: \Sigma^+ \rightarrow \Delta^+$ be a homomorphism, where $\#\Sigma = 3$. Then $T_3 \cup T_h \subset T_5$.

Proof:

Since $T_3 \subset T_5$ it suffices to prove that $T_h \subset T_5$.

Let $w \in T_h$.

Hence $w = a u b$ where $a, b \in \Sigma, u \in \Sigma^+$ and either $h(u) \text{ sub } h(a)$ or $h(a) \text{ sub } h(b)$. Hence a, b, u must be such that either $a \notin \text{alph}(u)$ or $b \notin \text{alph}(u)$. Thus $\#\text{alph}(u) \leq 2$. But $u \in SF(\Sigma^+)$ and so it must be that $|u| \leq 3$. Consequently $|w| \leq 5$ and the lemma holds. ■

Now Proposition 3 follows from Theorem 1 and Lemma 3. ■

(3.2) The following result concerning square freeness of uniform homomorphisms is proved in [Cr].

Proposition 4. Let $h: \Sigma^+ \rightarrow \Delta^+$ be a uniform homomorphism. Then h is square free if and only if $h(w) \in SF(\Delta^+)$ for each $w \in SF(\Sigma^+)$ such that $|w| \leq 3$.

■

This result follows also from our Theorem 1: it suffices to notice that if h is uniform then $T_h \subset T_3$.

(3.3) In [Cr] the following "numerical" characterization of square free homomorphisms improving the Berstel result is given.

Proposition 5. Let $h: \Sigma^+ \rightarrow \Delta^+$ be a homomorphism. Then h is square free if and only if $h(w) \in SF(\Delta^+)$ for each $w \in SF(\Delta^+)$ such that $|w| \leq \max \left\{ 3, \left\lceil \frac{\max(h) - 3}{\min(h)} \right\rceil \right\}$. ■

This result is also optional in the sense discussed under (2) above. However for particular homomorphisms it provides a better bound than our Theorem 2.

ACKNOWLEDGEMENTS

The authors greatly acknowledge the support of NSF grant MSC 79-03838.

REFERENCES

- [B] J. Berstel, Sur les mots sans carre definis par un morphisme, 1979, *Springer Lecture notes in Computer Science*, v. 71, 16-25.
- [Br] F. Brandenburg, Uniformly growing k-th power free homomorphisms, *Theoretical Computer Science*, to appear.
- [BEM] D.R. Bean, A. Ehrenfeucht and G.F. McNulty, Avoidable patterns in strings of symbols, 1979, *Pacific Journal of Mathematics*, v85, no.2, 261-293.
- [C] A. Cobham, Uniform tag sequences, *Mathematical Systems Theory*, 1972, v.6, n.2, 164-191.
- [Cr] M. Crochemore, Sharp characterizations of square free morphisms, 1982, *Theoretical Computer Science*, v. 18, 221-226.
- [D] F.M. Dekking, Combinatorial and statistical properties of sequences generated by substitutions, 1980, Ph.D. Thesis, University of Nijmegen, Holland.
- [ER] A. Ehrenfeucht and G. Rozenberg, On the subword complexity of square free DOL languages, 1981, *Theoretical Computer Science*, v. 16, 25-32.
- [K] J. Karhumaki, On cubic-free ω -words generated by binary morphisms, *Discrete Applied Mathematics*, to appear.
- [MH] M. Morse and G. Hedlund, Unending chess, symbolic dynamics and a problem of semigroups, 1944, *Duke Math. Journal*, v. 11, 1-7.
- [S1] A. Salomaa, Morphisms on free monoids and language theory, in R.V. Book, ed., *Formal language theory, perspectives and open problems*, 1980, Academic Press, London, New York, 141-166.
- [S2] A. Salomaa, *Jewels of formal language theory*, Computer Science Press, 1981.

- [T] A. Thue, Über unendliche Zeichenreihen, 1906, Norske Vid, Selsk, Skr., I
Mat. Nat. Kl., Christiania, v.7, 1-22.

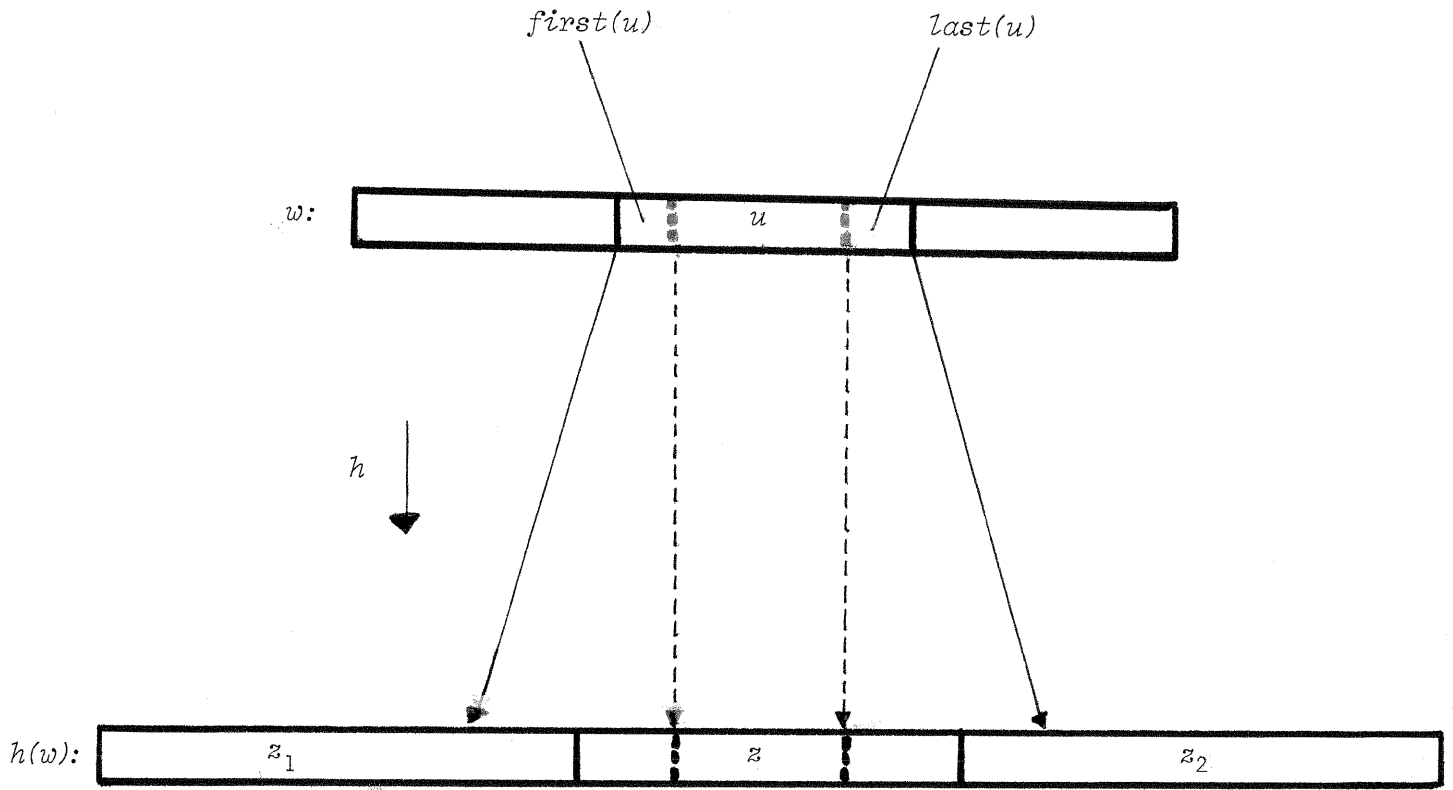

Figure 1

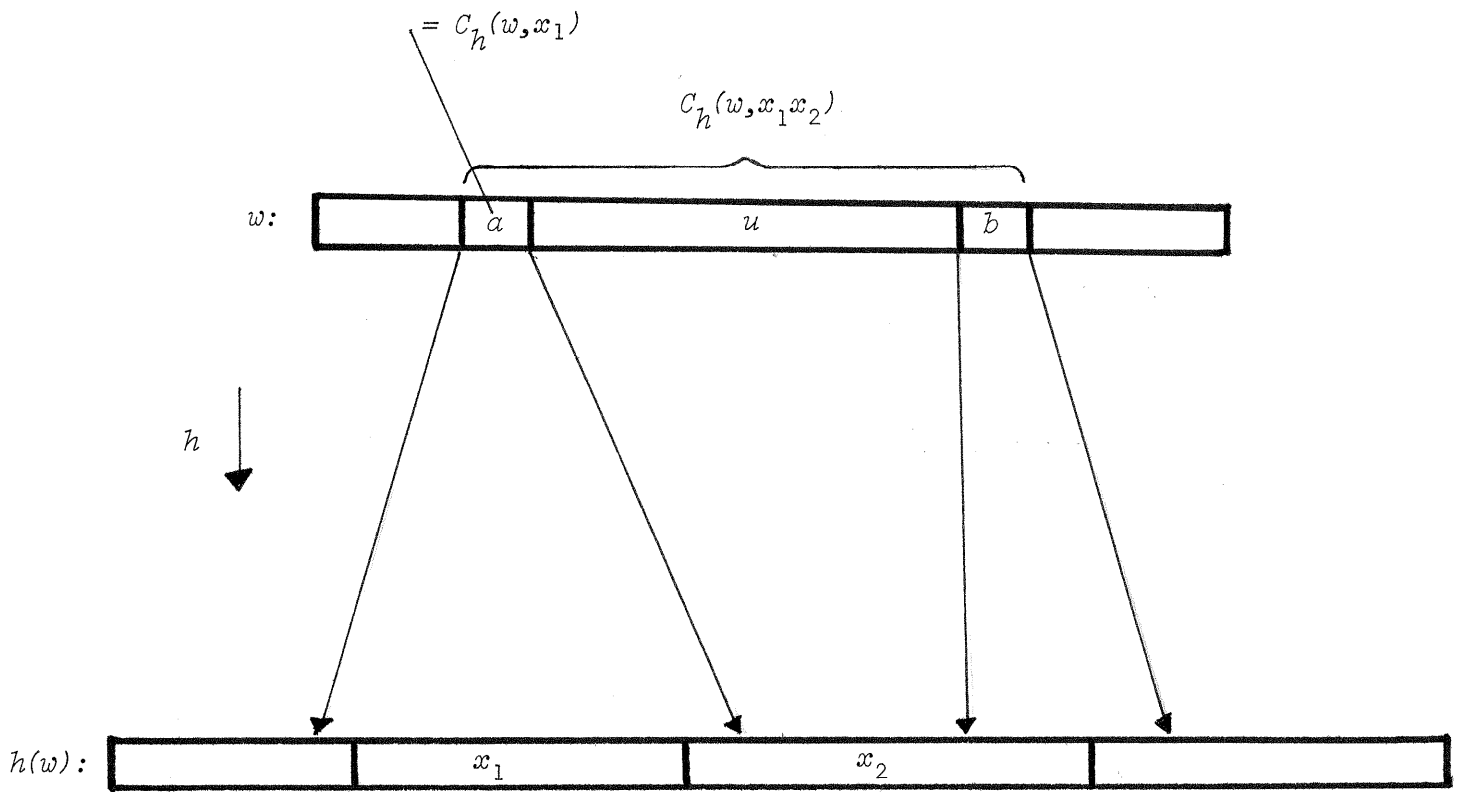

Figure 2

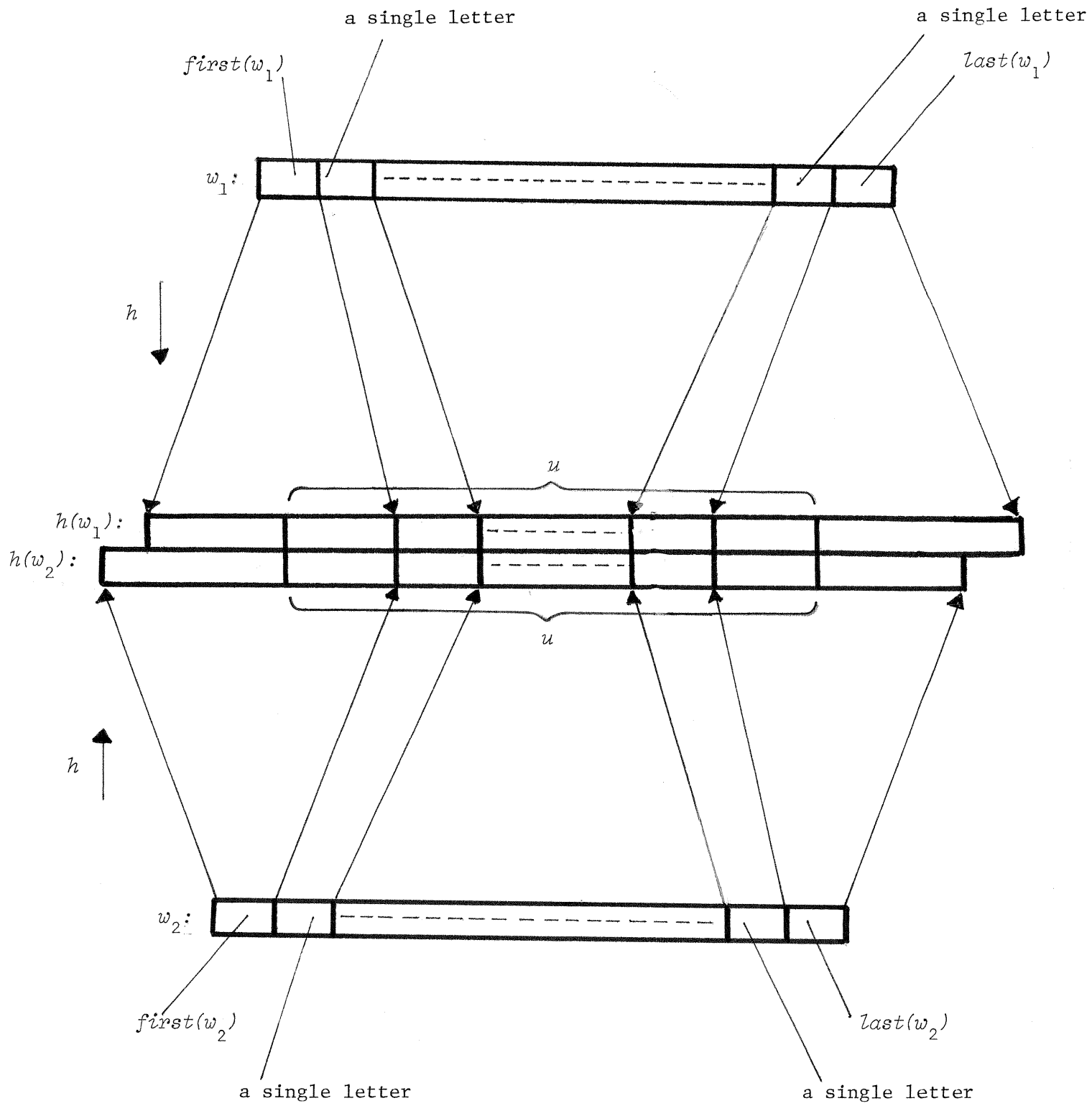

Figure 3

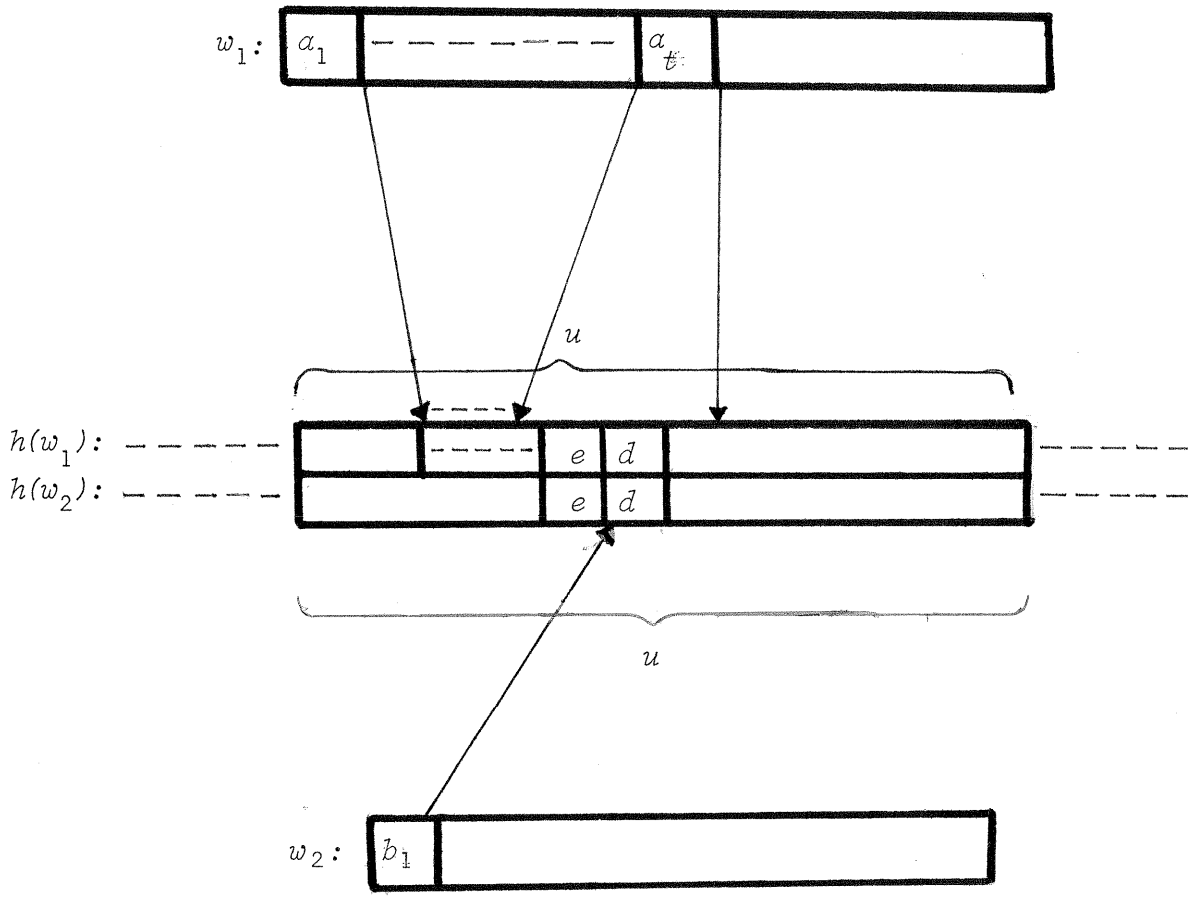

Figure 4

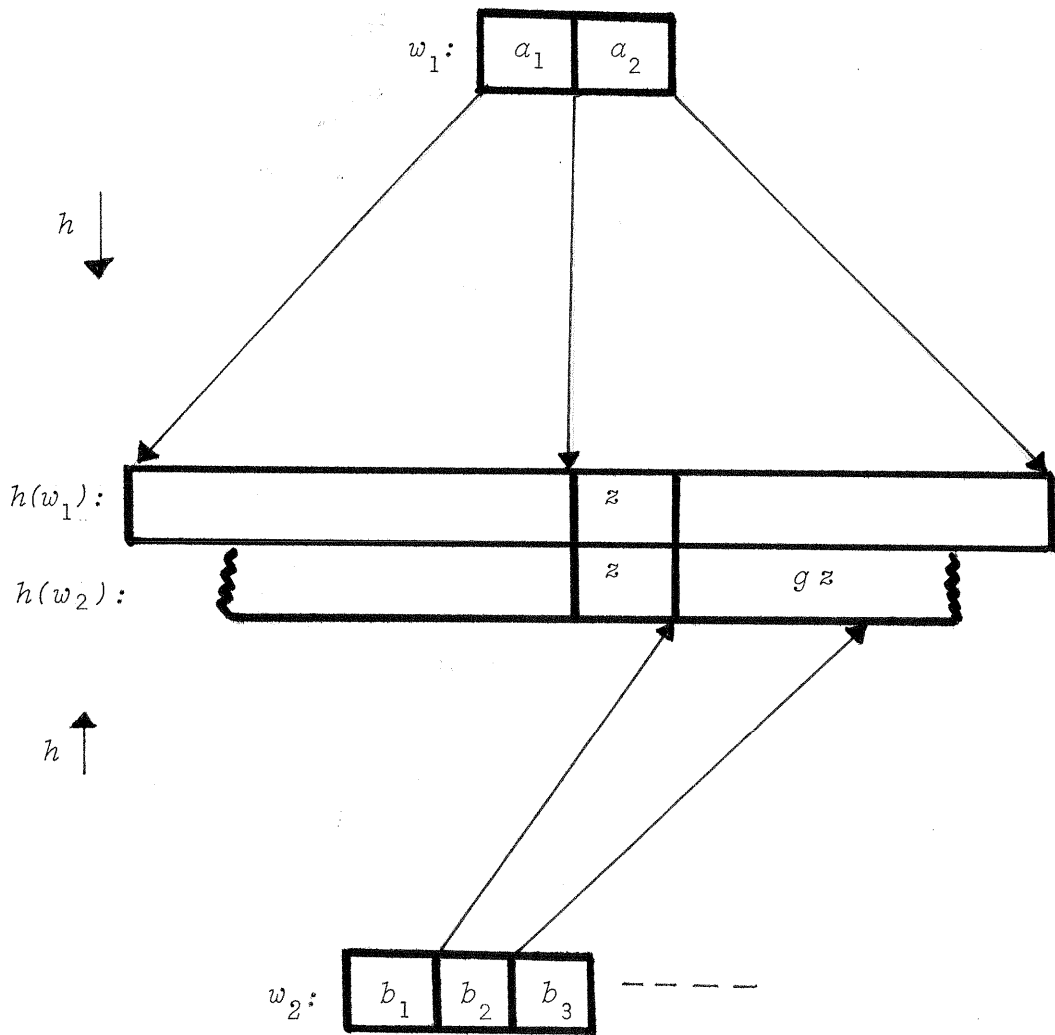

Figure 5

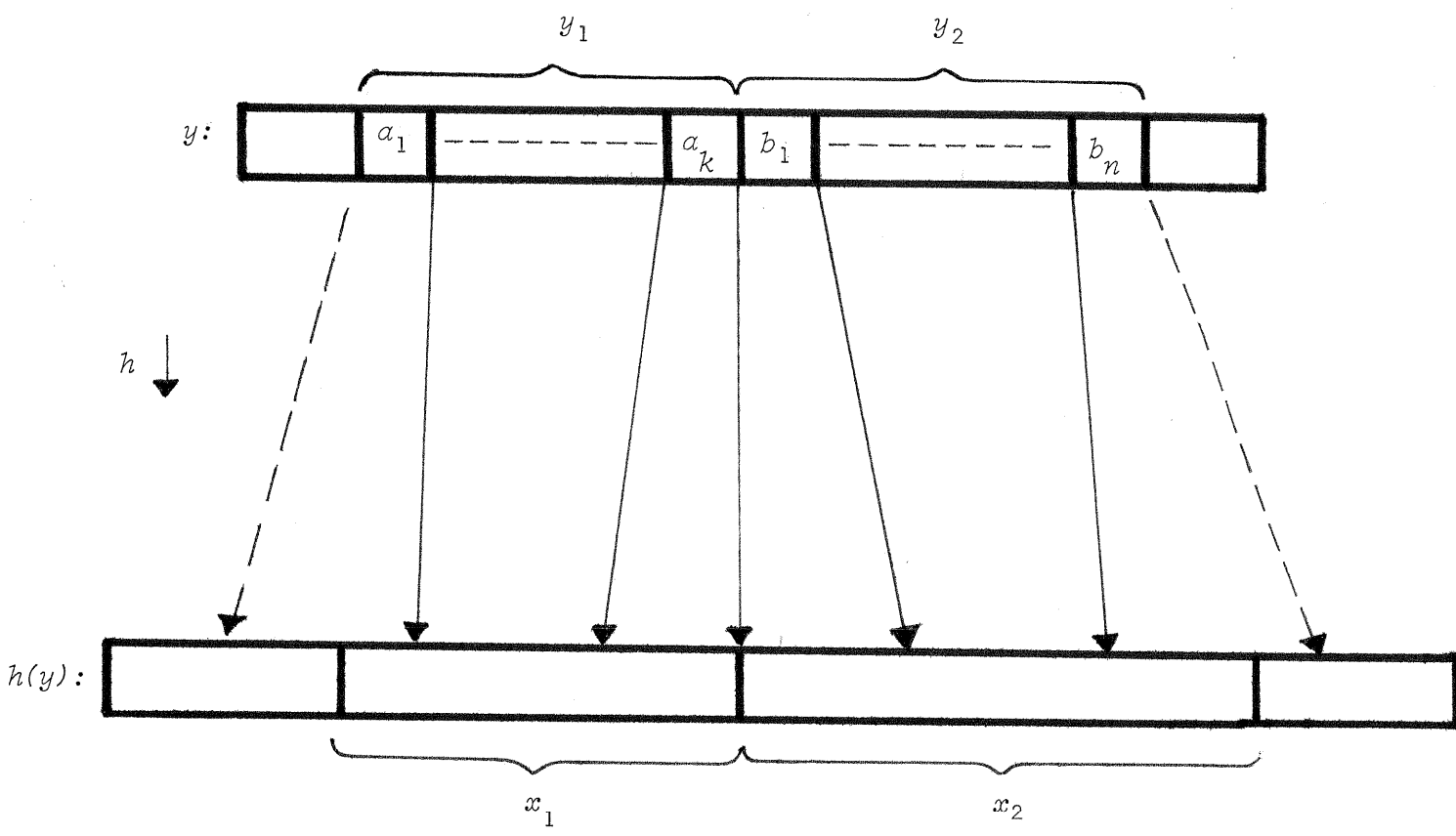

Figure 6

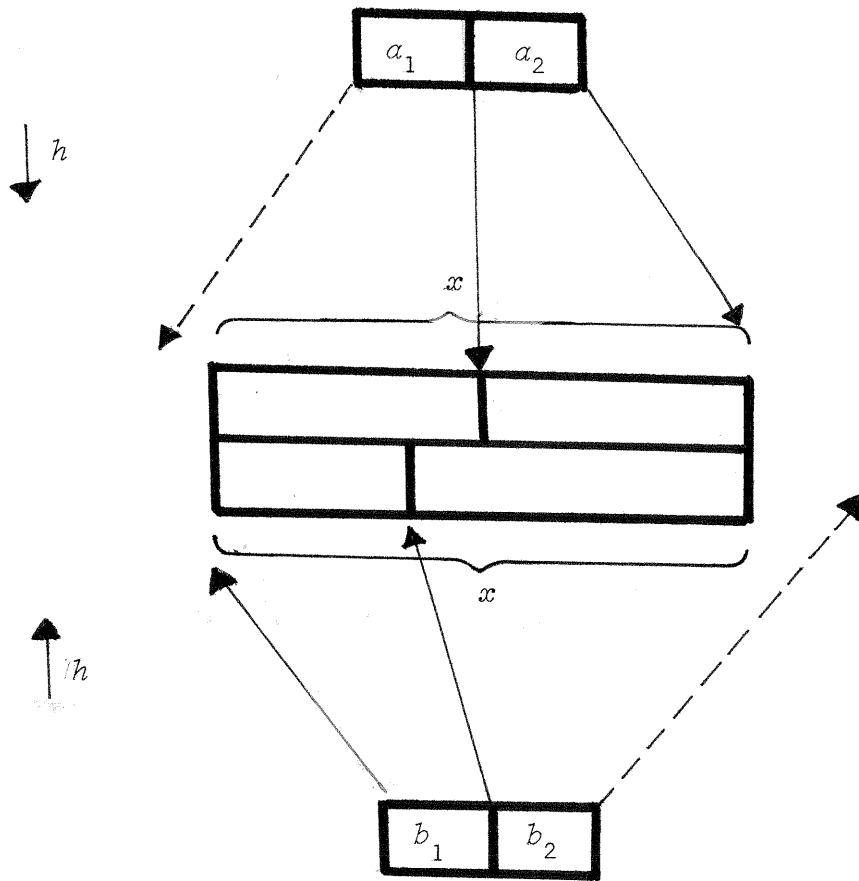

Figure 7

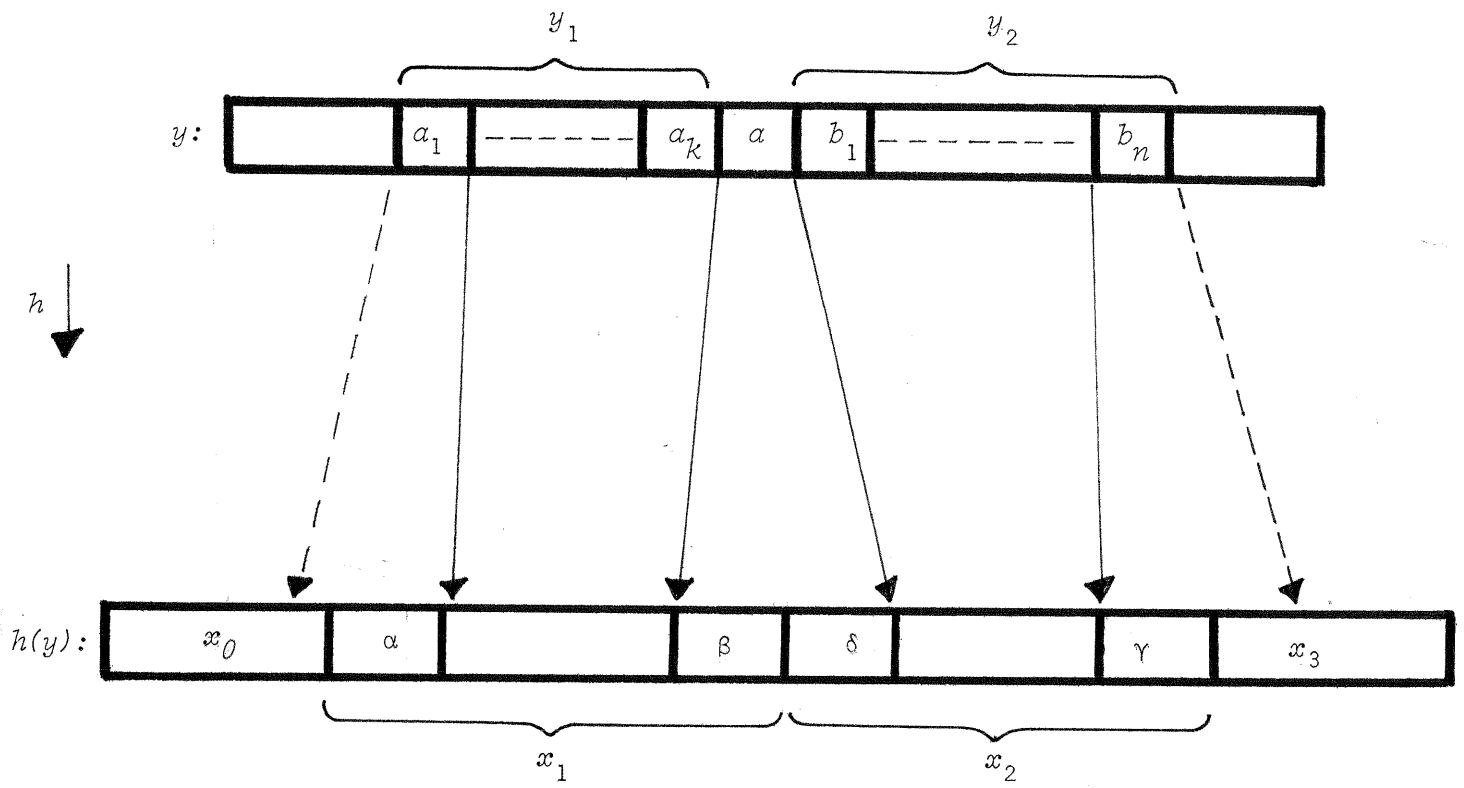

Figure 8